

PARÇA KODU PART CODE	PARÇA ADI PART NAME	ERKEK TERMINAL MALE TERMINAL	a ÖLÇÜSÜ (AYAR) a MEASURE (SET)	s ÖLÇÜSÜ (KALINLIK) s MEASURE (THICKNESS)	Malzeme Material	Kaplama / Coating		
						SN	AG	Nİ
MS 2107.50 RP	MINİ DİŞİ FİŞ 4.8 (0.50) =RP=	0.50	0.35±0.1	0.30±0.05	(CuZn30) Pirinç / Brass	-	-	-
MS 2107.50 RPK	MINİ DİŞİ FİŞ 4.8 (0.50) =RPK=	0.50	0.35±0.1	0.30±0.05	(CuZn30) Pirinç / Brass	+	-	-
TD 2107.30 RP	MINİ DİŞİ FİŞ 4.8 (0.30) =RP=	0.30	0.20±0.1	0.35±0.05	(CuZn30) Pirinç / Brass	-	-	-
TD 2107.40 RP	MINİ DİŞİ FİŞ 4.8 (0.40) =RP=	0.40	0.25±0.1	0.35±0.05	(CuZn30) Pirinç / Brass	-	-	-
TD 2107.50 DP	MINİ DİŞİ FİŞ 4.8 (0.50) =DP=	0.50	0.35±0.1	0.35±0.05	(CuZn30) Pirinç / Brass	-	-	-
TD 2107.50 RP	MINİ DİŞİ FİŞ 4.8 (0.50) =RP=	0.50	0.35±0.1	0.35±0.05	(CuZn30) Pirinç / Brass	-	-	-
TD 2107.50 RPK	MINİ DİŞİ FİŞ 4.8 (0.50) =RPK=	0.50	0.35±0.1	0.35±0.05	(CuZn30) Pirinç / Brass	+	-	-
TD 2107.50 RÇN	MINİ DİŞİ FİŞ 4.8 PASLANMAZ (0.50) =RÇN=	0.50	0.35±0.1	0.35±0.05	Nikel Sac / Nickel Sheet	-	-	+
TD 2107.60 RPK	MINİ DİŞİ FİŞ 4.8 (BARAN) (0.60) =RPK=	0.50	0.45±0.1	0.35±0.05	(CuZn30) Pirinç / Brass	+	-	-
TD 2107.80 DP	MINİ DİŞİ FİŞ 4.8 (0.80) =DP=	0.80	0.55±0.1	0.35±0.05	(CuZn30) Pirinç / Brass	-	-	-
TD 2107.80 RP	MINİ DİŞİ FİŞ 4.8 (0.80) =RP=	0.80	0.55±0.1	0.35±0.05	(CuZn30) Pirinç / Brass	-	-	-
TD 2107.80 RPK	MINİ DİŞİ FİŞ 4.8 (0.80) =RPK=	0.80	0.55±0.1	0.35±0.05	(CuZn30) Pirinç / Brass	+	-	-
TD 2107.80 RÇN	MINİ DİŞİ FİŞ 4.8 PASLANMAZ (0.80) =RÇN=	0.80	0.55±0.1	0.35±0.05	Nikel Sac / Nickel Sheet	-	-	+
TD 2107.90 RP	MINİ DİŞİ FİŞ 4.8 (0.90) =RP=	0.80	0.70±0.1	0.35±0.05	(CuZn30) Pirinç / Brass	-	-	-
TD 2107.90 RPK	MINİ DİŞİ FİŞ 4.8 (0.90) =RPK=	0.80	0.70±0.1	0.35±0.05	(CuZn30) Pirinç / Brass	+	-	-

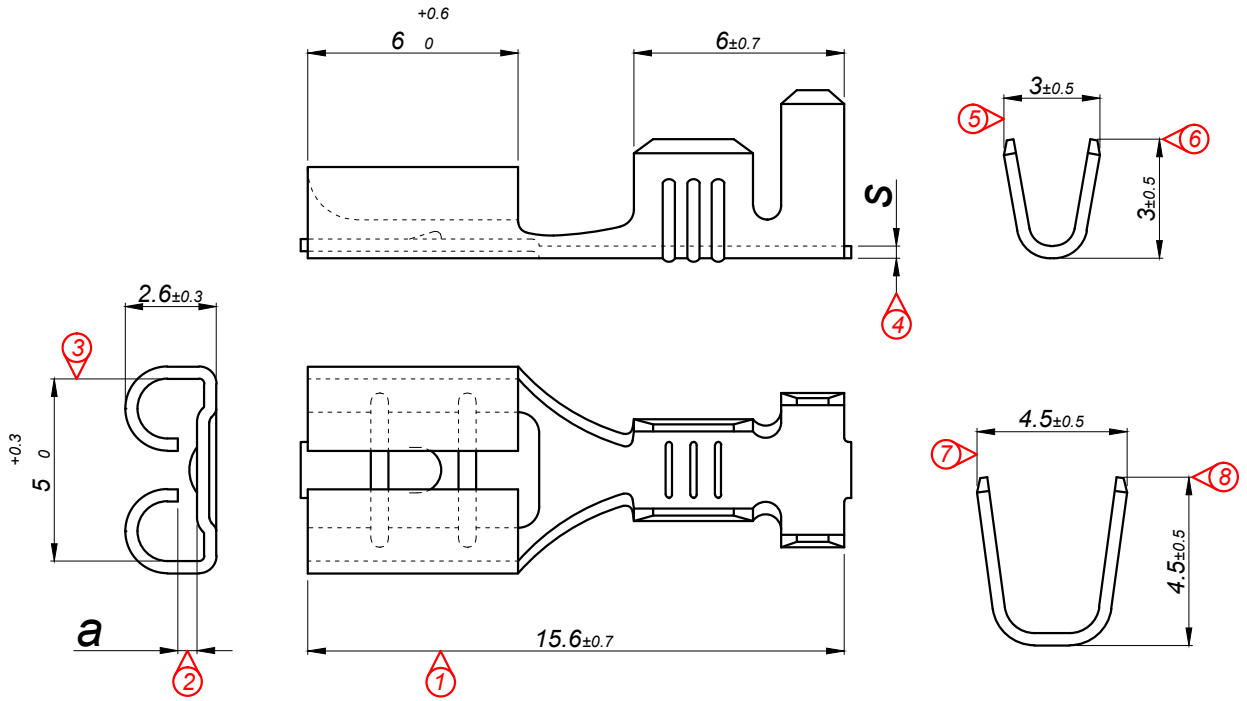

Kablo Kesiti

Wire Section : 0.5 - 1 mm²

Kalıp çıkış yönü
Mold output direction

Makara açılım yönü
Reel opening direction

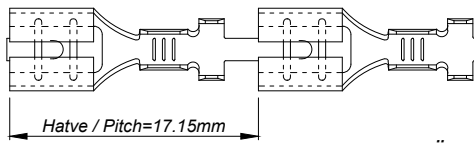

Ölçek
Scale : 2 / 1

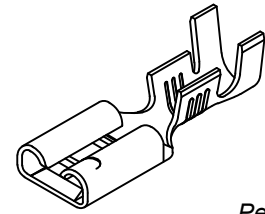

Perspektif
Perspective

Resim üzerinden ölçü almayınız
do not measure on drawing

Tarih / Date	06.06.2011	İmza / Signature	Ölçek / Scale		
Çizen / Desing	M. Yağcı		5 / 1		
Onay / Approval	S. Gölcük			No	Değişiklik / Revision
		Parça Adı: Part Name		Parça Kodu: Part Code	
		MINİ DİŞİ FİŞ 4.8		TD 2107	